

English

Operating manual

Albedometer

LPPYRA11



Members of GHM GROUP:

GREISINGER

HONSBURG

Martens

IMTRON

DeltaOHM

VAL.CO

www.deltaohm.com

Keep for future reference.

TABLE OF CONTENTS

1	INTRODUCTION	3
2	WORKING PRINCIPLE.....	4
3	INSTALLATION	6
4	ELECTRICAL CONNECTIONS.....	8
5	MEASUREMENT	9
6	MAINTENANCE.....	10
7	TECHNICAL SPECIFICATIONS	11
8	SAFETY INSTRUCTIONS	12
9	ORDERING CODES	13

1 INTRODUCTION

The LPPYRA11 albedometer measures the net global radiation, as well as the albedo of grounds (albedo is the ratio between diffuse radiation from a determined surface and the quantity of radiation that arrives on the surface).

The LPPYRA11 is manufactured mounting two LPPYRA10 pyranometers in one housing only. The upper pyranometer measures the incident radiation striking the ground [↓], while the lower pyranometer measures the reflected radiation [↑].

The output signals of the two pyranometers can be processed to get the desired physical quantity.

The LPPYRA11 can be used as a pyranometer for measuring global radiation. As a pyranometer, the LPPYRA11 is a Spectrally Flat Class A (Secondary Standard) pyranometer in accordance with ISO 9060:2018 and with the criteria of the WMO "Guide to Meteorological Instruments and Methods of Observation".

The albedometer is supplied factory calibrated and with a calibration report. The calibration is carried out in accordance with the ISO 9847:1992 (type IIc) standard: "Calibration of field pyranometers by comparison to a reference pyranometer". The pyranometer is calibrated by comparison with the reference sample calibrated annually at WRC (World Radiation Center).

2 WORKING PRINCIPLE

The LPPYRA11 albedometer is based on a pair of thermopile sensors, one of them measuring the incident radiation on the ground [↓] and the other one the reflected radiation [↑]. Each thermopile works as an independent pyranometer. The thermopile sensitive surface is coated with a black matt paint, which allows the pyranometer not to be selective at different wave lengths.

In order to grant the thermopile a proper thermal insulation from the wind and reduce the sensitivity to thermal irradiance, LPPYRA11 is equipped with two concentric domes having 50 mm and 32 mm outer diameter on each side. The domes protect the thermopile from the dust, which might change spectral sensitivity if it lies on the black surface.

The pyranometer spectral range is determined by the transmission of the two glass domes. Thanks to the use of a new material for the manufacturing of the domes, the spectral range has been further extended to short wavelengths starting from 283 nm.

Considering a standard solar spectrum, the portion of solar irradiation measured by the pyranometer is greater than 99.8%. Figure 2.1 shows the relative spectral sensitivity of the LPPYRA11 albedometer and a standard solar spectrum.

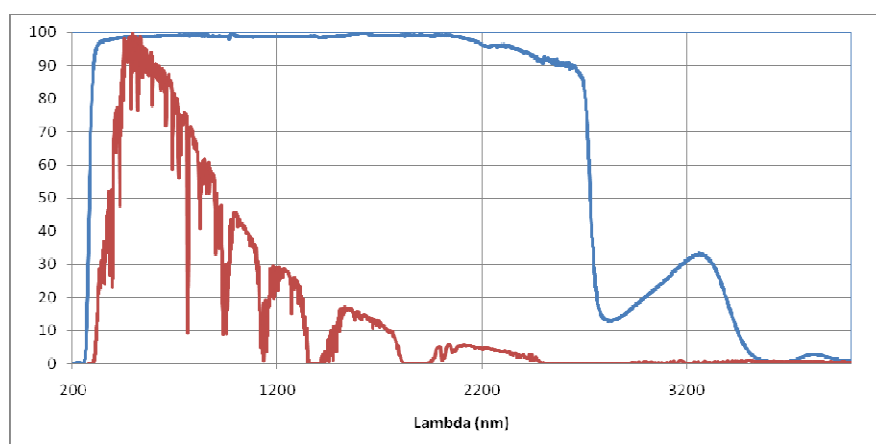

Fig. 2.1: LPPYRA11 albedometer relative spectral sensitivity (blue line) compared with a standard solar spectrum (red line)

Radiant energy is absorbed by the thermopile black surface, thus creating a difference of temperature between the center of the thermopile (hot junction) and the pyranometer body (cold junction). Thanks to the Seebeck effect, the difference of temperature between hot and cold junction is converted into a Difference of Potential.

A second thermopile, not accessible by light, is mounted inside the instrument. This second thermopile, connected in anti-series with respect to the sensor exposed to light, reduces the signals due to sudden temperature changes of the pyranometer (thermal shocks).

In order to minimize sensitivity changes with temperature, LPPYRA11 is equipped with a passive compensation circuit. The graph in figure 2.2 shows the typical variation of sensitivity at different temperatures. The deviations are calculated from the sensitivity measured at 20 °C.

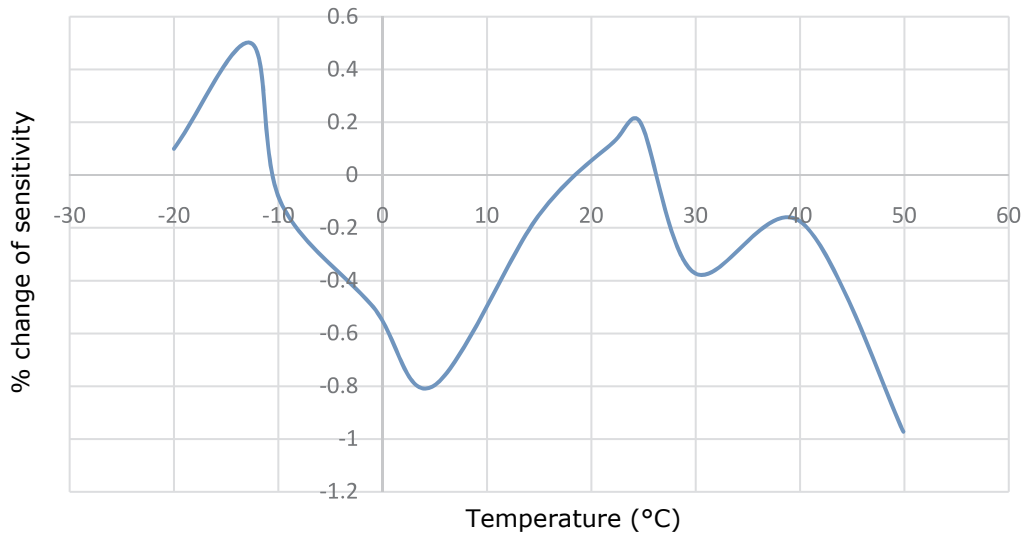

Fig. 2.2: : percentage change of LPPYRA11 albedometer sensitivity in the temperature range -20...50 °C compared to the sensitivity at 20 °C

To prevent internal condensation forming on the internal side of the dome under certain climatic conditions, silica gel tablets are inserted inside the pyranometer to absorb humidity.

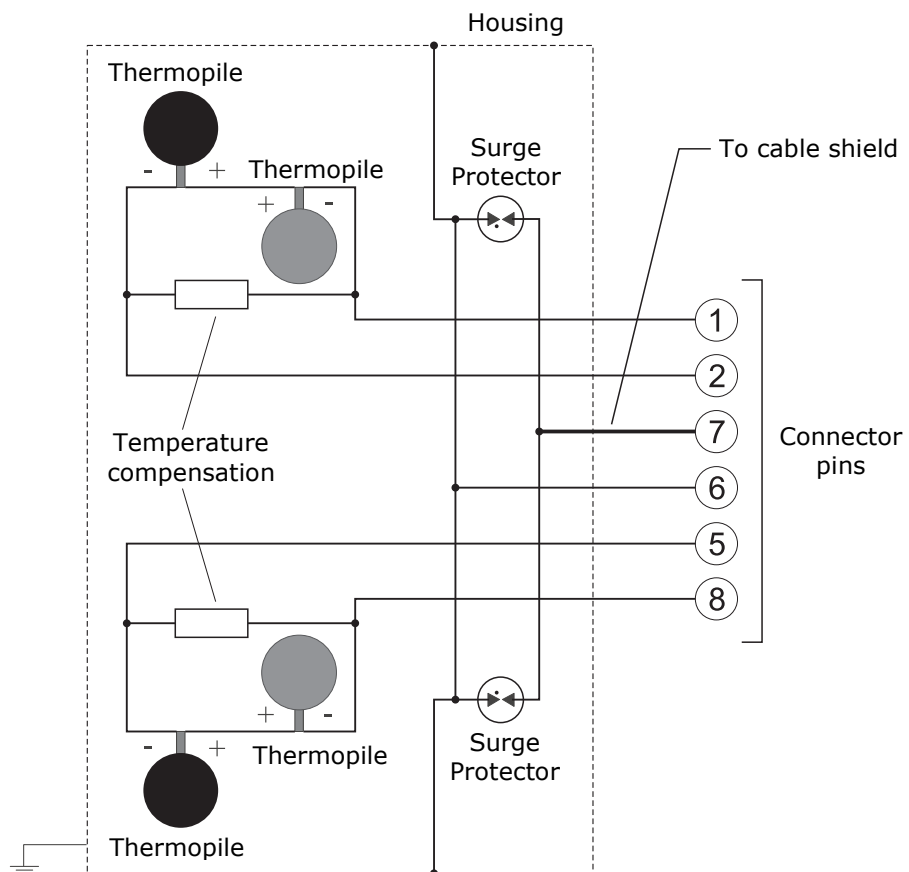

Fig. 2.1: scheme of principle LPPYRA11

3 INSTALLATION

Before installing the albedometer, refill the cartridge containing silica-gel crystals. Silica gel absorbs humidity in the dome chamber and prevents, in particular climatic conditions, condensation on the internal walls of the domes and measurement alteration.

Do not touch the silica gel crystals with your hands while refilling the cartridge. Carry out the following instructions in an environment as drier as possible:

1. Loosen the three screws that fix the white shade disk.
2. Unscrew the silica gel cartridge using a coin.
3. Remove the cartridge perforated cap.
4. Open the sachet containing silica gel (supplied with the pyranometer).
5. Fill the cartridge with the silica gel crystals.
6. Close the cartridge with its own cap, paying attention that the sealing O-ring be properly positioned.
7. Screw the cartridge to the pyranometer body using a coin.
8. Check that the cartridge is screwed tightly (if not, silica gel life will be reduced).
9. Position the shade disk and screw it with the screws.
10. The albedometer is ready for use.

The figure below shows the operations necessary to fill the cartridge with the silica gel crystals.

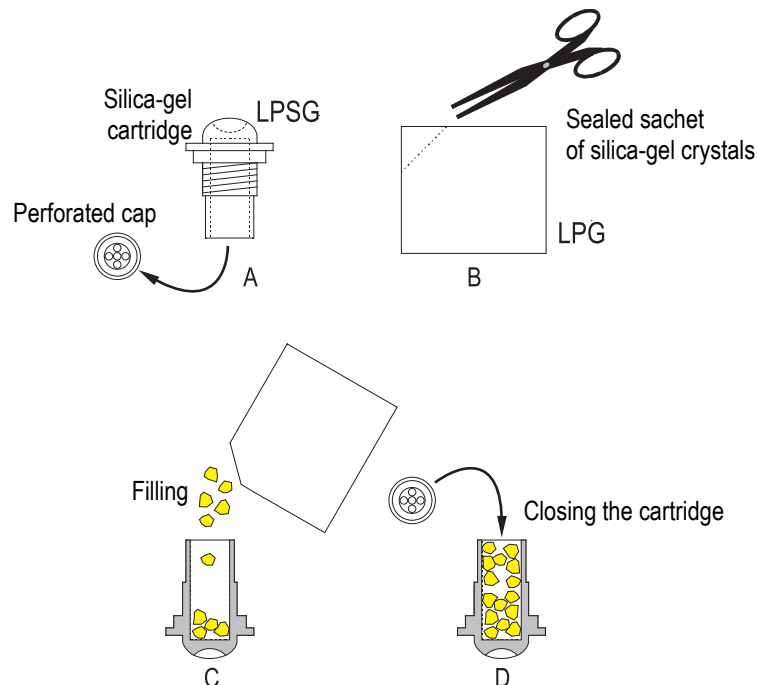

Fig. 3.1: filling the silica-gel cartridge

- Mount the albedometer 1 – 2 m above the ground. Grass should be kept at the same height all the year long. In snowy regions, keep the instrument above the blanket of snow so that the distance from the albedometer to the snow be constant.
- The albedometer must be mounted in an easy-to-reach location in order to clean the dome regularly and carry out maintenance. At the same time, make sure that no buildings, constructions, trees or obstructions exceed the horizontal plane where the upper pyranometer lies. If this is not possible, select a site where obstructions in the path of the sun from sunrise to sunset do not exceed 5 degrees of elevation.
N.B.: The presence of obstructions on the horizon line affects significantly the measurement of direct irradiance.
- The pyranometer must be located far from any kind of obstruction, which might reflect sunlight (or sun shadow) onto the pyranometer itself.
- In compliance with ISO TR9901 standard and WMO recommendations, when the pyranometer is used without the white shade disk, it must be positioned so that its connector is pointed to the North Pole, if the instrument is used in the Northern Hemisphere, and to the South Pole, if used in the Southern Hemisphere. In any case, it is better to follow this suggestion even when the shade disk is applied.
- The mounting can be made using the rod provided with the instrument. In order to allow an accurate horizontal positioning, the pyranometer is equipped with a levelling device. The mast height does not exceed the pyranometer plane to avoid measurement errors caused by any reflection or shadow of the mast itself.
- It is preferably to thermally insulate the pyranometer from its mounting bracket ensuring, at the same time, a good electrical contact to ground.

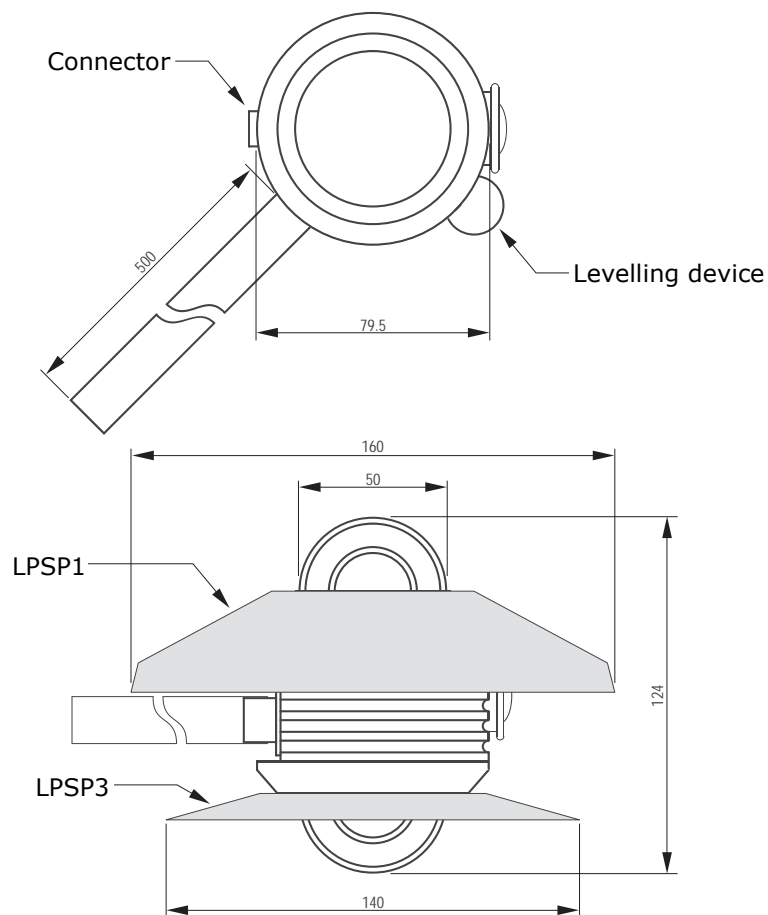

Fig. 3.2: fixing and dimensions

4 ELECTRICAL CONNECTIONS

LPPYRA11 has a 8-pole connector and uses the **CPM12AA8... optional** cables, with 8-pole connector on one side and open wires on the other side.



The metallic housing of the albedometer should preferably be grounded (\perp) locally. In this case, do not connect the wire of the cable corresponding to the housing to prevent ground loops.

Only if it is not possible to ground locally the metallic case of the albedometer, connect the wire of the cable corresponding to the housing to ground (\perp).

The albedometer LPPYRA11 is passive and does not require power supply. It is to be connected either to a millivoltmeter or to a data acquisition system (with at least two inputs). Typically, the albedometer output signal does not exceed 20 mV. In order to better exploit the albedometer features, the readout instrument should have 1 μ V resolution.

Connector	Function	Color
1	Output positive (+Vout) upper pyranometer [\downarrow]	Red
2	Output negative (-Vout) upper pyranometer [\downarrow]	Blue
3	Not connected	
4	Not connected	
5	Output negative (-Vout) lower pyranometer [\uparrow]	Brown
6	Housing (C)	White
7	Cable shield (SH)	Black
8	Output positive (+Vout) lower pyranometer [\uparrow]	Green

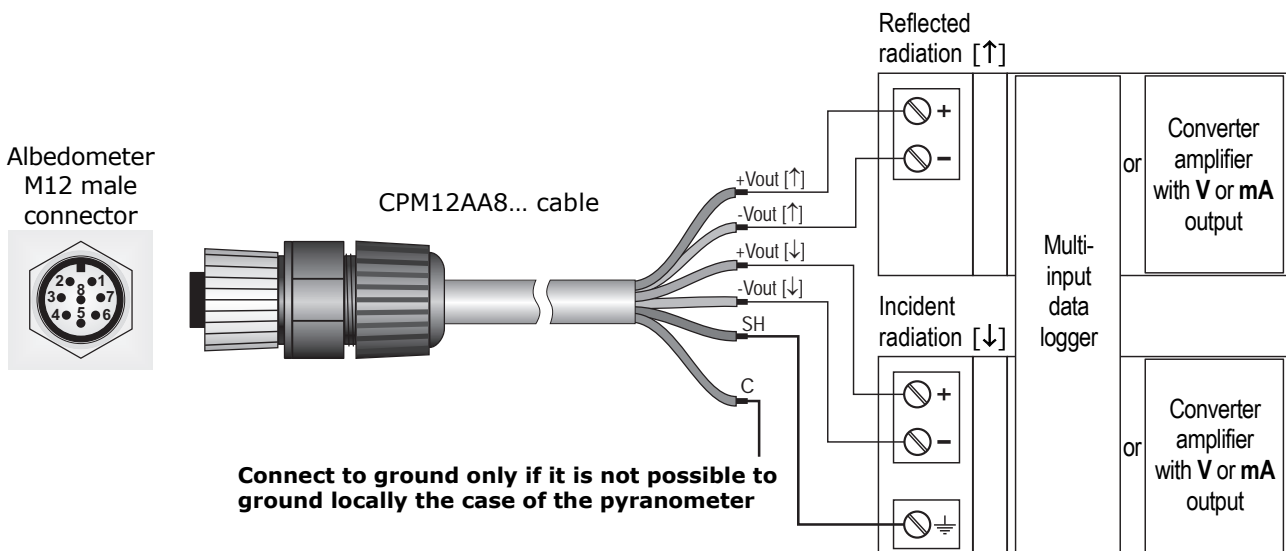

Fig. 4.1: LPPYRA11 connections

The cable shield is isolated from the albedometer housing by means of two gas surge arrestors, which prevents lightnings to damage the sensor. The shield has to be connected to the same ground as the readout instrument. Best safety is achieved through a perfect connection between housing and earth.

5 MEASUREMENT

Each of the two pyranometer that make up the albedometer is distinguished by its own sensitivity (or calibration factor) **S** expressed in $\mu\text{V}/(\text{Wm}^{-2})$ and shown in the label on the pyranometer (and in the calibration report).

The irradiance **E_e** is obtained by measuring with a multimeter the difference of potential **DDP** at the ends of the sensor and applying the following formula:

$$E_e = DDP / S$$

where:

E_e is the irradiance expressed in W/m^2 ;

DDP is the difference of potential expressed in μV measured by the multimeter;

S is the sensitivity of the albedometer expressed in $\mu\text{V}/(\text{Wm}^{-2})$.

Albedo is the fraction of solar radiation that is reflected from the ground, with respect to incident radiation:

$$ALBEDO = E_e [\uparrow] / E_e [\downarrow]$$

With the albedometer it is possible to calculate the net radiation making the difference between the incident global radiation and the reflected global radiation.

6 MAINTENANCE

In order to grant measurements high accuracy, it is important to keep the outer glass domes clean. Consequently, the more the domes will be kept clean, the more measurements will be accurate.

You can wash it using water and standard papers for lens. If necessary, use pure ETHYL alcohol. After using alcohol, clean again the domes with water only.

Because of the high temperature changes between day and night, some condensation might appear on the domes of the pyranometers. In this case the performed reading is highly over-estimated. To minimize the condensation, the albedometer is provided with a cartridge containing dessicant material (silica-gel). The efficiency of the silica-gel crystals decreases over time while absorbing humidity. Silica-gel crystals are efficient when their color is **yellow**, while they turn **white/translucent** as soon as they loose their efficiency. Read instructions at chapter 3 about how to replace the silica-gel crystals. Silica-gel typical lifetime goes from 2 to 6 months depending on the environment where the albedometer works.

To exploit all the albedometer features, it is highly recommended that the calibration be checked annually.

7 TECHNICAL SPECIFICATIONS

Sensor	Thermopile
Typical sensitivity	6÷11 $\mu\text{V}/\text{Wm}^{-2}$
Impedance	5÷50 Ω
Measuring range	0÷4000 W/m^2
Viewing angle	2 π sr
Spectral range (50%)	283÷2800 nm
Operating temperature/humidity	-40÷80 °C / 0÷100%
Output	Analog in $\mu\text{V}/\text{Wm}^{-2}$
Connection	8-pole M12 connector
Dimensions	Fig. 3.2
Weight	1.35 kg approx. (complete albedometer)
Accuracy of levelling device	< 0.1°
Protection degree	IP 67
MTBF	> 10 years

Technical Specifications According to ISO 9060

Classification	Spectrally Flat Class A
Response time (95%)	< 5 s
Zero offset	
a) response to a 200 W/m^2 thermal radiation	< $ \pm 7 \text{ W}/\text{m}^2$
b) response to a 5 K/h change in ambiente temperature	< $ \pm 2 \text{ W}/\text{m}^2$
c) total zero offset including the effects a), b) and other sources	< $ \pm 10 \text{ W}/\text{m}^2$
Long-term instability (1 year)	< $ \pm 0.5 \%$
Non-linearity	< $ \pm 0.2 \%$
Response according to the cosine law	< $ \pm 10 \text{ W}/\text{m}^2$
Spectral error	< $ \pm 0.2 \%$
Temperature response (-10...+40°C)	< 1 %
Tilt response	< $ \pm 0.2 \%$

8 SAFETY INSTRUCTIONS

General safety instructions

The instrument has been manufactured and tested in accordance with the safety standard EN61010-1:2010 "Safety requirements for electrical equipment for measurement, control and laboratory use" and has left the factory in perfect safety technical conditions.

The instrument proper operation and operating safety can be ensured only if all standard safety measures as well as the specific measures described in this manual are followed.

The instrument proper operation and operating safety can be ensured only in the climatic conditions specified in this manual.

Do not use the instruments in places where there are:

- Corrosive or flammable gases.
- Direct vibrations or shocks to the instrument.
- High-intensity electromagnetic fields, static electricity.

User obligations

The instrument operator shall follow the directives and regulations below that refer to the treatment of dangerous materials:

- EEC directives on workplace safety.
- National law regulations on workplace safety.
- Accident prevention regulations.

9 ACCESSORIES ORDERING CODES

LPSP1	UV-resistant shade disk for the upper pyranometer (spare part).
LPSP3	UV-resistant shade disk for the lower pyranometer (spare part).
CPM12AA8...	Cable with 8-pole M12 connector on one end, open wires on the other end. Length 2 m (CPM12AA8.2), 5 m (CPM12AA8.5) or 10 m (CPM12AA8.10).
LPSG	Cartridge to contain desiccant silica-gel crystals, complete with O-ring and cap (spare part).
LPG	Pack of 5 sachets of silica-gel crystals.

DELTA OHM metrology laboratories LAT N° 124 are ISO/IEC 17025 accredited by ACCREDIA for Temperature, Humidity, Pressure, Photometry / Radiometry, Acoustics and Air Velocity. They can supply calibration certificates for the accredited quantities.

NOTES



DICHIARAZIONE DI CONFORMITÀ UE
EU DECLARATION OF CONFORMITY

Delta Ohm S.r.L. a socio unico – Via Marconi 5 – 35030 Caselle di Selvazzano – Padova – ITALY

Documento Nr. / Mese.Anno: **5139 / 07.2019**
Document-No. / Month. Year :

Si dichiara con la presente, in qualità di produttore e sotto la propria responsabilità esclusiva, che i seguenti prodotti sono conformi ai requisiti di protezione definiti nelle direttive del Consiglio Europeo:
We declare as manufacturer herewith under our sole responsibility that the following products are in compliance with the protection requirements defined in the European Council directives:

Codice prodotto: **LPPYRA11**
Product identifier :

Descrizione prodotto: **Albedometro**
Product description : **Albedometer**

I prodotti sono conformi alle seguenti Direttive Europee:
The products conform to following European Directives:

Direttive / Directives	
2014/30/EU	Direttiva EMC / EMC Directive
2014/35/EU	Direttiva bassa tensione / Low Voltage Directive
2011/65/EU - 2015/863/EU	RoHS / RoHS

Norme armonizzate applicate o riferimento a specifiche tecniche:
Applied harmonized standards or mentioned technical specifications:

Norme armonizzate / Harmonized standards	
EN 61010-1:2010	Requisiti di sicurezza elettrica / Electrical safety requirements
EN 61326-1:2013	Requisiti EMC / EMC requirements
EN 50581:2012	RoHS / RoHS

Il produttore è responsabile per la dichiarazione rilasciata da:
The manufacturer is responsible for the declaration released by:

Johannes Overhues

Amministratore delegato
Chief Executive Officer

Caselle di Selvazzano, 19/07/2019

Questa dichiarazione certifica l'accordo con la legislazione armonizzata menzionata, non costituisce tuttavia garanzia delle caratteristiche.
This declaration certifies the agreement with the harmonization legislation mentioned, contained however no warranty of characteristics.

WARRANTY

Delta OHM is required to respond to the "factory warranty" only in those cases provided by Legislative Decree 6 September 2005 - n. 206. Each instrument is sold after rigorous inspections; if any manufacturing defect is found, it is necessary to contact the distributor where the instrument was purchased from. During the warranty period (24 months from the date of invoice) any manufacturing defects found will be repaired free of charge. Misuse, wear, neglect, lack or inefficient maintenance as well as theft and damage during transport are excluded. Warranty does not apply if changes, tampering or unauthorized repairs are made on the product. Solutions, probes, electrodes and microphones are not guaranteed as the improper use, even for a few minutes, may cause irreparable damages.

Delta OHM repairs the products that show defects of construction in accordance with the terms and conditions of warranty included in the manual of the product. For any dispute, the competent court is the Court of Padua. The Italian law and the "Convention on Contracts for the International Sales of Goods" apply.

TECHNICAL INFORMATION

The quality level of our instruments is the result of the continuous product development. This may lead to differences between the information reported in the manual and the instrument you have purchased. In case of discrepancies and/or inconsistencies, please write to sales@deltaohm.com. Delta OHM reserves the right to change technical specifications and dimensions to fit the product requirements without prior notice.

DISPOSAL INFORMATION

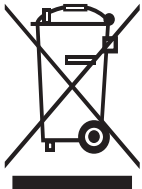

Electrical and electronic equipment marked with specific symbol in compliance with 2012/19/EU Directive must be disposed of separately from household waste. European users can hand them over to the dealer or to the manufacturer when purchasing a new electrical and electronic equipment, or to a WEEE collection point designated by local authorities. Illegal disposal is punished by law.

Disposing of electrical and electronic equipment separately from normal waste helps to preserve natural resources and allows materials to be recycled in an environmentally friendly way without risks to human health.



V1.2
21/04/2021