

Monitoring and Controlling Energy Efficiency of Photovoltaic Installations

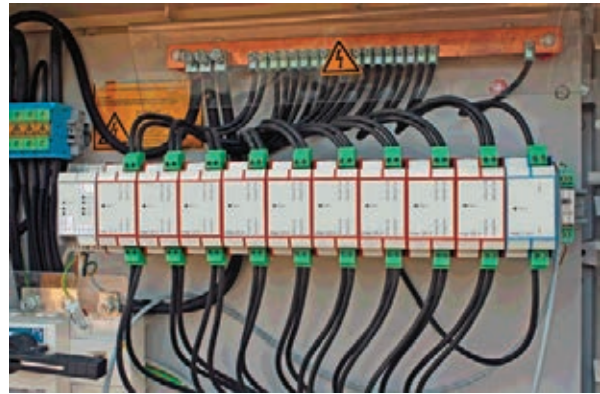
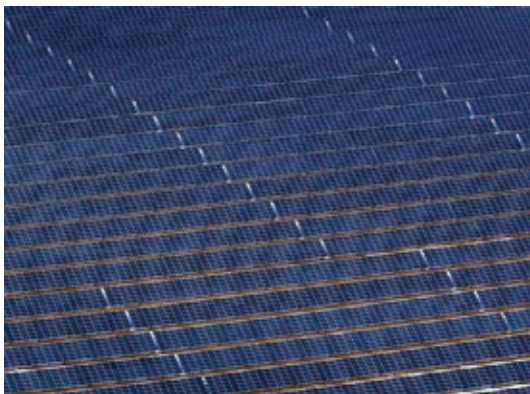

Features

System	Current and voltage supervision of solar panels Control of switching states
Sources	Shunt and inductive sensors in string arrays Standard signals from temperature, wind speed, and irradiation sensors Door switches Digital outputs of power inverters

Applications

- Solar Power Plants
- Off-Grid Systems
- Roof Systems

Functions and Benefits

Installations generating green energy have to be operated economically and efficiently to feed in a maximum of energy. For that consistent information about their efficiency is absolutely mandatory. Permanent control also provides early detection of defects and malfunction of a PV system or its solar panels. Further on additional access control and equipment condition monitoring should be set up.

Data and state acquisition of the PV system is designed with modular components. There are modules measuring DC current and voltage of the individual strings, modules for panel temperature, and signals of wind speed and irradiation sensors.

Digital-In modules monitor e.g. switching states of door switches and inverters.

The individual DIN-rail modules are mounted in open-field array boxes or in a local indoor control cabinet as needed by application and quantity. There they are linked each time via an internal bus with an intelligent communication unit transmitting the collected data over a field bus (Modbus RS485 or CAN) to the next higher control level.

The modular design allows manifold combinations and upgradings.

So the modules are not just suited for large power plants, but also for monitoring of medium and small power installations.

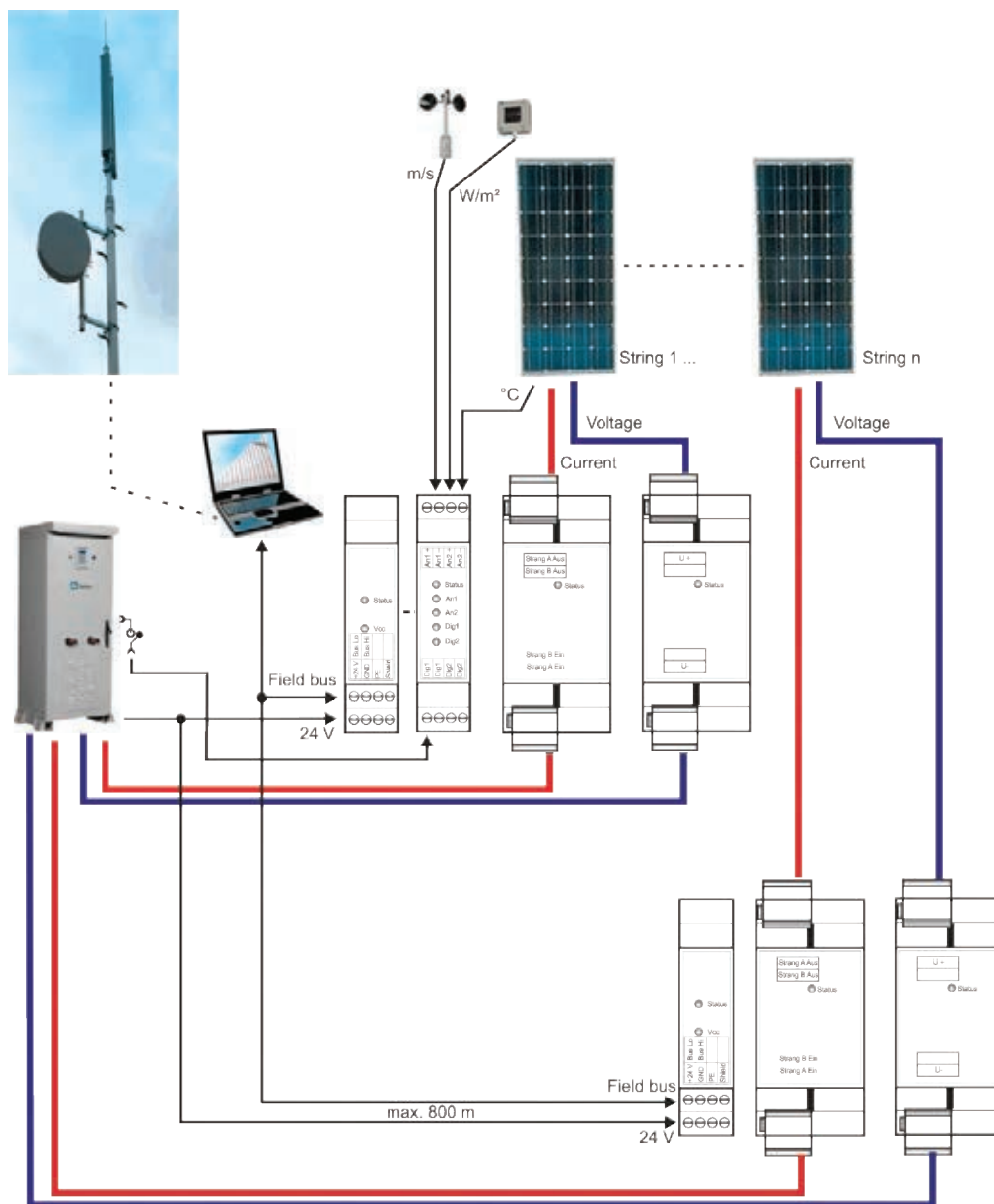

Product information

The current-to-voltage characteristic of a solar panel built of several solar cells connected in series, reflects the specific properties of this power generator. The curve of a solar panel is very similar to a single cell, despite the different scale factor. Solar panels are again connected in series or in parallel to generate more current or voltage as appropriate.

Under normal conditions the characteristic curve is like:

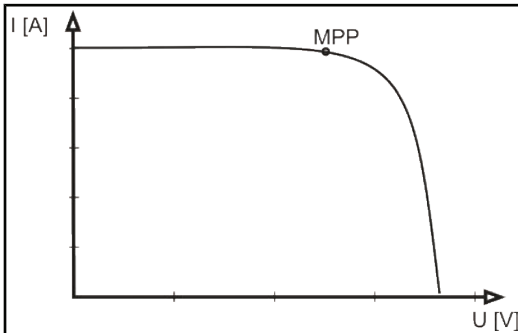

Fig. 1 Schematic view of IV characteristic

Voltage value at MPP is approximately 80% open circuit voltage of a solar panel.

MPP (Maximum Power Point) is the operating point with maximum power as product of cell current and voltage:

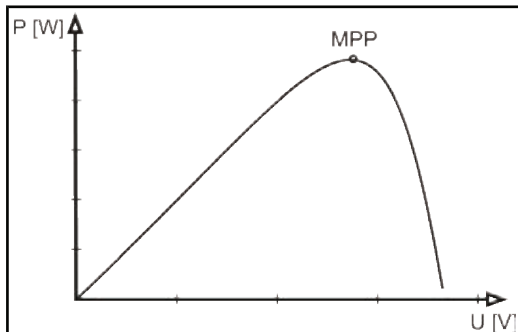

Fig. 2 Schematic view of maximum power characteristic

From the characteristics it can be learned how important it is, that the operating voltage of the panels is not suppressed too much below the MPP, avoiding potential energy losses. Degradation of cells by internal or external influences over time can be seen instantly from the measured curves. Depending on how many panels are combined to a string, occurring malfunctions can also be localized physically precise.

The energy efficiency of the strings is also remarkably dependent on a mismatch caused by e.g. shadowing of cells or different input resistances.

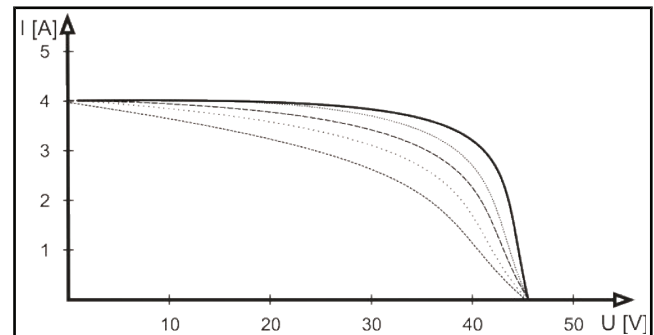

Fig. 3 Schematic view of shadowing impact within a 10..75 % range (solid line ideal characteristic)

The output current of a solar panel is proportional to incident solar radiation. Maximum radiated power on earth is in the range of 800 to 1200 W/m².

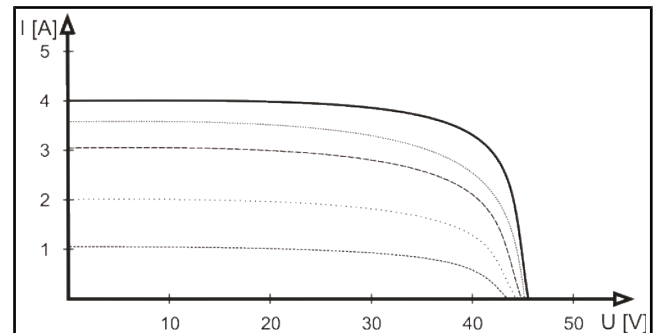

Fig. 4 Schematic view of irradiation impact within 100 to 1000 W/m² (solid line)

The energy yield of a panel is determined by its cell with the lowest yield. Degradation of cells by internal or external influences over time, can be seen instantly from the measured curves. Depending on how many panels are combined to a string, yield losses can also be localized physically precise.

Product information

The energy yield of solar panels is also affected by cell temperature, as cell voltage is decreasing with increasing temperature. For reference, temperature in an array is measured exemplarily at a characteristic spot.

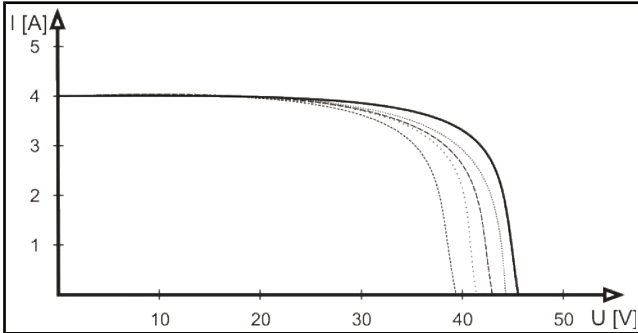

Fig. 5 Schematic view of temperature impact within (from left) +80..25 °C (solid line)

Temperature measurement can be done with a temperature transmitter with signal current or voltage output . Pt100 sensors can be used directly with optional adaptation of the AD module.

Data from wind speed and irradiation sensors via signal current or voltage transmitters can also be acquired and incorporated in the monitoring of the installation.

Switching states of e.g. doors can be supervised with the digital input module. This accommodates safety aspects (security control) or shutdown of inverters.

The following listed measurement devices guarantee efficient monitoring of PV systems' energy yield. Further on malfunction of or in strings depending on the layout of the monitoring system can be recognized quickly, avoiding potential energy and financial losses with it.

Device Overview

Module	Input						Output			Page
	Voltage	Current	Signal Voltage	Signal Current	Pt100	Digital-Out	Internal (SPI)	Modbus RS 485	CAN	
IPV Voltage	●						●			5
IPV Current		●					●			5
IPV Signals AD			○	○	○	●	●			6
IPV Signals D						●	●			6
IPV Communication								●	○	7

● Standard, ○ Optional, ● per type of sensor

Mistakes reserved, technical specifications subject to change without notice