



## HD2013 TIPPING BUCKET RAIN GAUGE

The HD2013 is a reliable and sturdy bucket rain gauge, built entirely from corrosion resistant materials in order to guarantee its durability. So as to ensure accurate measurement even with low temperature climatic conditions or during and after precipitations of snow, a version with a heater which is automatically activated around +4°C has been developed so that snow deposits and ice formations are prevented.

The rain gauge is formed by a metal base on which a tipping bucket is set. The rain collector cone, fixed to the aluminium cylinder, channels the water inside the tipping bucket: once the predefined level is reached, the calibrated bucket rotates under the action of its own weight, discharging the water. During the rotation phase, the usually closed reed contact opens for a fraction of a second, sending an impulse to the counter.

The quantity of rainfall measured is based on the count of the number of times the bucket is emptied: the reed contacts, usually closed, open at the moment of the rotation between one bucket's section and the other. The number of impulses can be detected and recorded by a **datalogger such as the DeltaOhm**

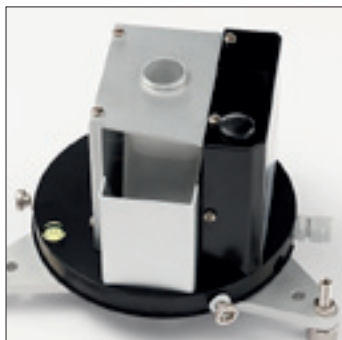

Inside view



Electrical connections

HD2013-DB or by a pulse counter.

A removable filter for periodic cleaning and maintenance is inserted in the water collector cone so as to prevent leaves or other elements blocking the end of the hole. For better water flow, the collector cone is treated with a non-stick paint. The HD2013R, the version with a heater, operates using either 12Vdc or 24Vdc voltage (to be specified in the order) and uses about 165W. Heating is activated around +4°C.

**When submitting your order**, upon request a bird dissuader, made of 8 3mm-diameter spikes, 60 mm in height, can be installed on the rain gauge.

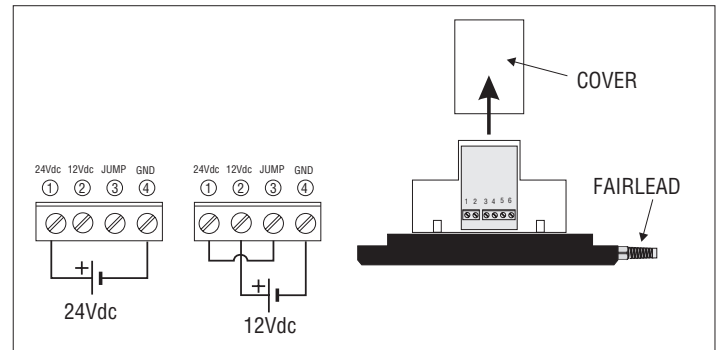

Fig. 1 Electrical connections

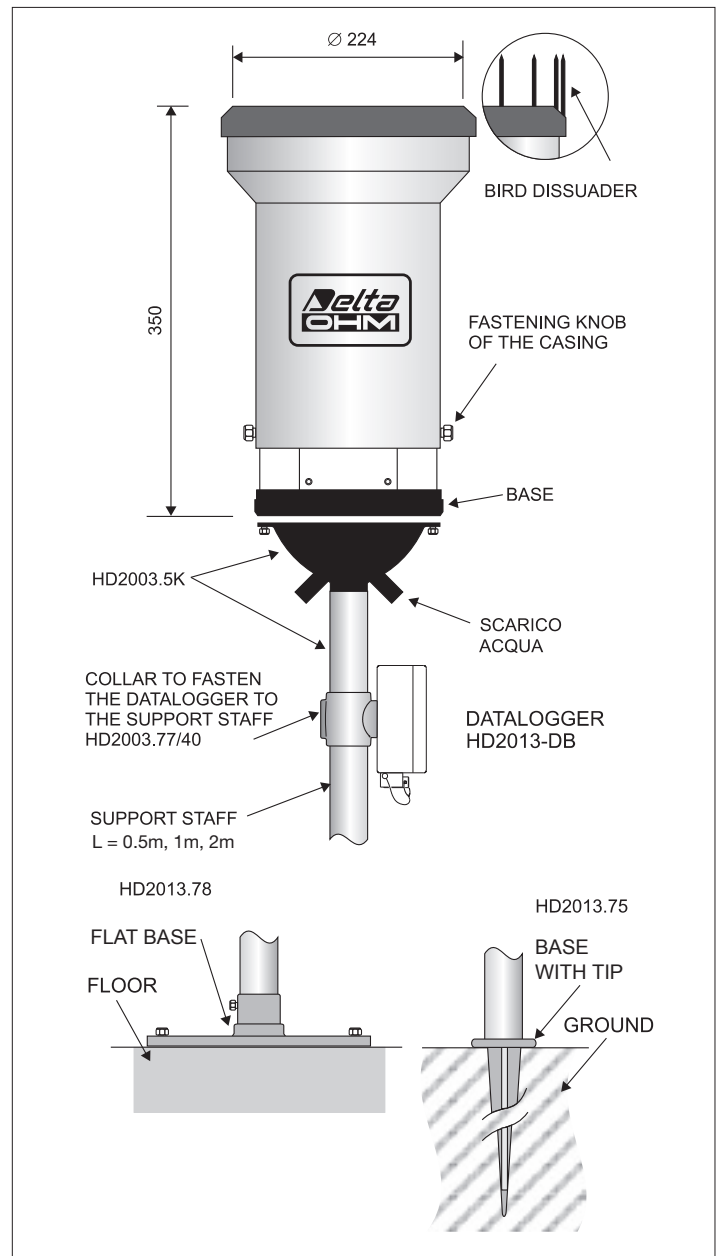

Fig. 2 Mechanical dimensions, installation systems

## INSTALLATION AND MAINTENANCE

Upon request the rain gauge can be supplied ready calibrated at 0.2mm of rain per commutation of the bucket (upon request, 0.1 or 0.5 mm calibration can be provided): the calibration value is shown on the instrument's label.

The instrument must be installed in an open area, away from buildings, trees, etc..., ensuring the space over it is free from all objects which could obstruct rain measurements, and in an easily accessible position for the filter to be cleaned periodically.

Avoid installation in areas exposed to gusts of wind, turbulence (for example the top of a hill) as these may distort the measurements.

The rain gauge can be installed on the ground or raised 0.5 m, 1m or 2m above the ground.

Three adjustable support feet have been provided for ground installation so that the instrument can be levelled correctly, and the holes aligned so that it can be fixed to the floor.

For raised installations a collar has been provided which fastens around the base of the instrument on which the support staff must be inserted. The staff may end with either a flange so that it can be fixed to the floor, or a tip to be driven into the ground. The various fastening systems can be seen in fig. 2.

For the tipping device to function correctly and so for the measurement to be correct, it is important that the instrument is placed perfectly level. The base of the rain gauge is fitted with a bubble level.

For installation, unscrew the three screws at the sides of the cylinder that supports the water collector cone.

**Note:** a heating resistor is fitted around the cone vertex in the **HD2013R** version. To disconnect the power leads, the terminal block's protection cover must be removed and the connector plugged into the heater's leads coming from the cone needs disconnecting (see fig. 3).

## Electrical connection

For the version without heating use a 2-wire cable with 0.5 mm<sup>2</sup> minimum wires section, for the version with heating use a 4-wire cable with 2.5 mm<sup>2</sup> minimum wires section. Use a shielded cable over long distances. Slide the cable through the cable gland and fasten it with the cable fastener located near the entry hole at the base of the rain gauge. Unscrew the terminal block protection cover and perform the connections as shown in figure 3. **The rain gauge output, indicated at point 1 in the figure, must be connected to the input of the HD2013-DB rain gauge data logger (please see the details in the manual of the data logger) or to a pulse counter or to a data logger.**

The heated version requires power (12 Vdc or 24 Vdc depending on the version supplied) for the resistors: perform the connection as indicated at fig. 1. If the connections are set correctly, the LED placed near the terminals will be lit up.

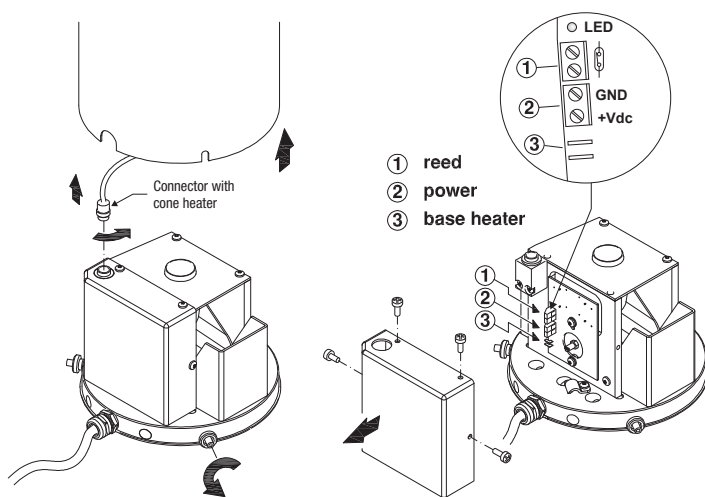

Fig. 3 – Electrical connections (version with heating option)

## Maintenance

Verify filter cleanliness periodically; check that there is no debris, leaves or anything else that might obstruct the passage of water.

Check that the tipping bucket contains no dirt, sand, ... deposits, or any other obstruction.

If necessary, the surface can be cleaned with mild non aggressive detergent.

## Technical characteristics

	HD2013R	HD2013
Power	12Vdc or 24Vdc $\pm 10\%$ / 165W (to be specified in the order)	---
Type of output contact	NC contact (opens during commutation)	
Resolution	0.1 - 0.2 or 0.5 mm/commutation (on request at the time of placing the order)	
Precision	See normalized curve in fig.4. The curve is normalized at 0.2mm /commutation@50mm/h. If HD2013-DB data logger is employed, the measure can be automatically normalized according to this curve.	
Operating temperature range	-20°C ... +60°C	+4°C ... +60°C
Heater intervention temperature	+4°C	---
Protection degree	IP64	
Collector area	400 cm <sup>2</sup>	
Minimum sections of the wires of the connection cable	0,5mm <sup>2</sup> for the version without heating (HD2013) 2,5mm <sup>2</sup> for the version with heating (HD2013R)	

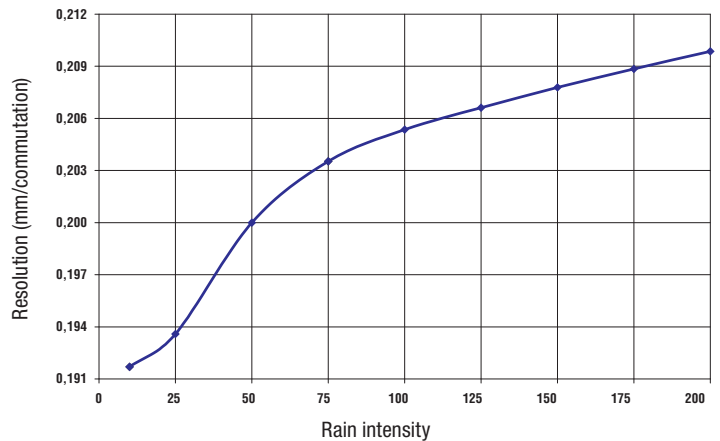

Fig. 4 Resolution according to the rain intensity



Rain gauge installed on the ground.

Rain gauge with bird dissuader.

## ORDER CODES

- HD 2013:** Rain gauge with tipping bucket, area 400cm<sup>2</sup>, for temperature range +4°C... +60°C. Resolutions to be specified at order 0.1, 0.2 or 0.5 mm. Output contact normally closed.
- HD 2013 R:** Rain gauge with tipping bucket, area 400cm<sup>2</sup>, equipped with heater for temperature range -20°C... +60°C. Resolutions to be specified at order 0.1, 0.2 or 0.5 mm. Output contact normally closed. Power voltage 12Vdc or 24Vdc ± 10% / power absorption 165W.
- HD 2013.18:** Bird spike.
- HD 2003.5K:** Accessory kit for the installation of the rain gauge raised 500 mm from ground, formed by water collection cup with threaded shaft for support bar L = 500 mm.
- HD 2003.5K1:** Accessory kit for the installation of the rain gauge raised 1 m from ground, formed by water collection cup for the rain gauge, support bar L = 1 m.
- HD 2003.5K2:** Accessory kit for the installation of the rain gauge raised 2 m from ground, formed by water collection cup for the rain gauge, support bar L = 2 m, accessories HD2003.75K for bracing the mast for installation with pegs on the ground.
- HD 2003.5K3:** Accessory kit for the installation of the rain gauge raised 2 m from ground, formed by water collection cup for the rain gauge, support bar L = 2 m, accessories HD2003.78K for bracing the mast for installation on the floor.
- HD 2013L:** Device for levelling the rain gauge when it is installed on a support bar. The adjustment is performed by means of fine pitch screws.
- HD 2003.75:** Flange with tip for the ground to support the raised from the ground rain gauge (to add to the accessory kits HD2003.5K...).
- HD 2003.78:** Level base for fastening the raised from the ground rain gauge (to add to the accessory kits HD2003.5K...).
- HD 2003.77/40:** Clamping to fasten the data logger HD2013-DB to the support staff



Bubble level

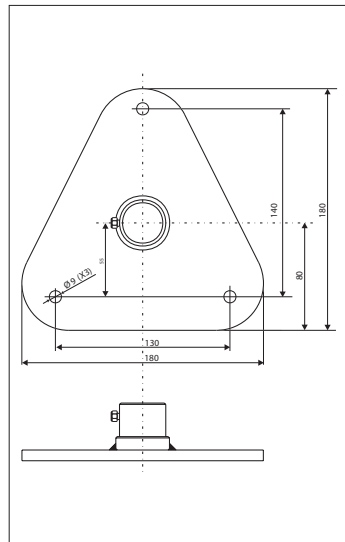

Base for ground fastening HD2013.78



Tip for ground for rain gauge raised from ground



Support plate for rain gauge raised from ground